

User Manual CX plus



Beluk GmbH
Taubenstrasse 1
86956 Schongau
Germany

Tel.: +49/(0)8861/2332-0
Fax.: +49/(0)8861/2332-22
E-Mail: blr@beluk.de
Web: <http://www.beluk.de>

 **DANGER**



General safety notes

Failure to observe the following instructions may result in serious injury or death!

There is a risk of electric shock during installation! Therefore, electrical devices may only be installed, operated, serviced and maintained by qualified professionals. A professional is someone who has the ability, experience and knowledge required for the construction, installation and operation of electrical equipment and who has been instructed in identification and avoidance of possible hazards.

During installation and maintenance, the relevant regulations for the installation of switchgear and accident prevention must be observed and adhered to.

Devices with damaged or open housings or terminals must not be operated on the power grid and must be disconnected immediately.

After disconnecting the device, 10 minutes must be waited until the capacitors have been discharged. Subsequently, doors or covers may be removed. It must be checked whether the disconnected area is voltage-free using a standardized measuring instrument.

Ther BELUK GmbH assumes no responsibility or warranty for damage to persons and equipment caused by improper installation and use.

Connection diagram: CX plus -12R

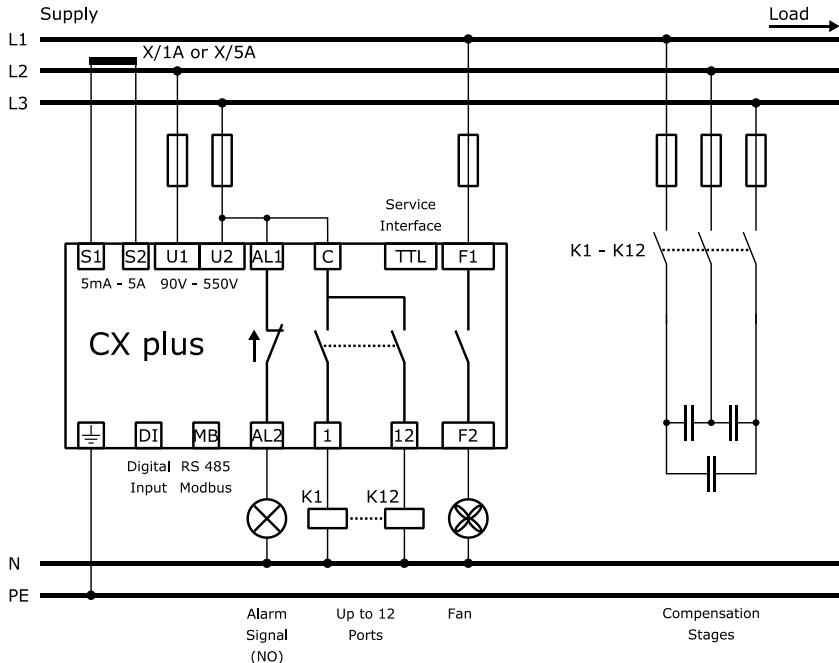

NOTE: The CX plus is designed to control **capacitive or inductive** stages. Operating both stage types simultaneously is not possible.

Connection diagram: CX plus -12T

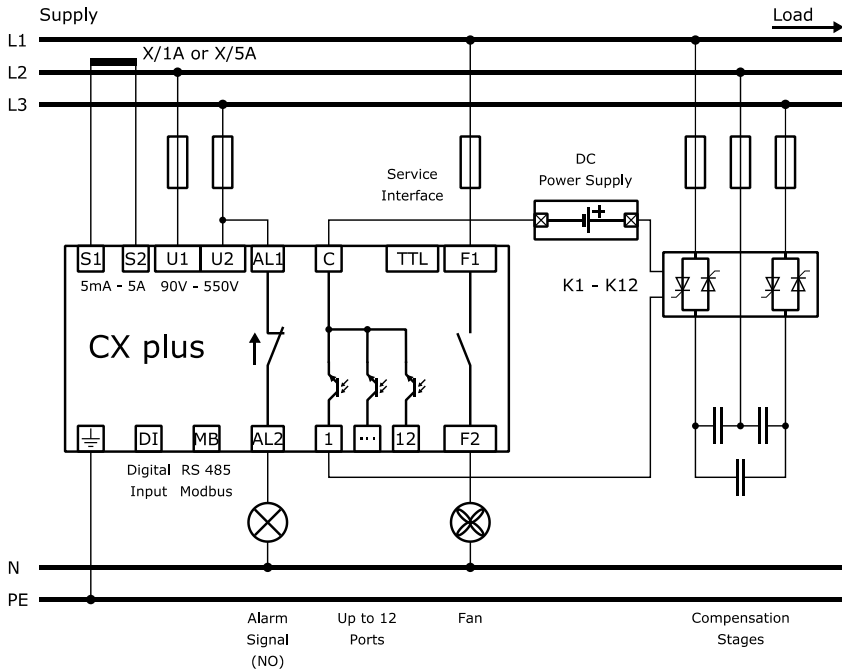

NOTE: The CX plus is designed to control **capacitive or inductive** stages. Operating both stage types simultaneously is not possible.

Installation and commissioning

- 1) Before installation, the connection specifications of the CX plus must be compared with the data of the power grid.
- 2) Disconnect the power supply and secured the working area against unauthorized and unintentional reconnection. Check if the disconnected area is voltage-free using a standardized measuring instrument. The voltage-free system must be earthed and short-circuited. Neighboring live parts must be covered and/or bypassed.
- 3) The current transformer must be short-circuited. A current transformer which has not been short-circuited generates a life-threatening voltage. This can lead to a destruction of the current transformer.
- 4) Insert the CX plus into the panel cut-out and fix it by using both fixing clamps.
- 5) Connect the grounding cable to the intended terminal on the backside of the device.
- 6) All cables must be connected as it is depicted in the connection diagram. The terminal K of the current transformer must be connected to terminal S1 and the terminal L to terminal S2.
- 7) Remove the short-circuit bridge at the current transformer.
- 8) The voltage can now be switched on.

- 9) If the device is connected correctly, the display will light up for one second and all symbols will be displayed during a display test.
- 10) Now the **First Setup** can be started by confirming **YES**. The different settings must be adjusted according to the power grid.
- 11) After a successful **First Setup**, the display shows **AUTO**. The control starts after the set discharge time has been expired.

Frequently asked questions during commissioning

- 1) **AUTO is not shown** → control is switched off
Possible reasons: Manual operation activated; control is switched off; temperature is too high; current is less than 5 mA; voltage or THD of the voltage are inadmissible
- 2) **U ALARM is shown** → voltage is out of tolerance
Possible reasons: Nominal voltage (SETUP/Un) or voltage transformer factor is set incorrectly (SETUP/Pt)
- 3) **I Lo ALARM is shown** → measuring current is smaller than 5 mA
Possible reasons: Connection from the current transformer to the controller is incorrect; the current transformer jumper was not removed; current transformer ratio is too large; no current flow
- 4) **EXPORT is shown** → reverse current flow
Possible reasons: If there is no real reverse current flow, the voltage or current measurement is incorrect (phase, polarity)
- 5) **Wrong cos φ is shown** → incorrect connection
Possible reasons: Voltage or current measurement is incorrect (phase, polarity)
- 6) **Outputs are immediately switched off**
Possible reasons: Stage sizes in the stage database are incorrect
- 7) **Frequent switching operations**
Possible reasons: Capacitor capacity have not been recognized yet

Display

INFO
AUTO
MANUAL
SETUP
ALARM

AUTO or

no display:

Measurement menu

INFO:

Stage database

AUTO:

Control is active (no menu item)

MANUAL:

Manual mode

SETUP:

Controller settings

ALARM:

Alarm memory

NT
EXPORT

ALARM

NT:

Target-cos φ 2 active

EXPORT:

Reverse current flow

ALARM:

Flashes if an alarm is pending

8.88 ic
1 2

First line

1: Power factor cos φ / Menu item

2: Inductive i / capacitive c

1 2 3
COS φ THDHar PΔQSUI 8.88.88 kMC% φ s VAWvarh

Second line

1: Abbreviations

2: Measurement values / alarm codes

3: Units

Stage outputs

Stage status:

On, off, faulty (flashing)

Stage data base:

Selected stage flashes

1 2 3 4 5 6 7 8 9 10 11 12 13

Operation concept

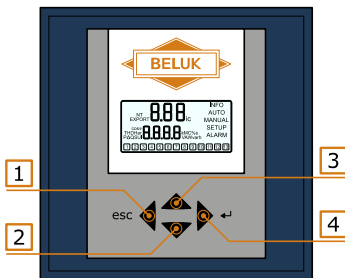

1

- Exit menu
- Move cursor to the left
- Reset alarm (push for 3 s)

2

- Decrease value
- Select next value, menu or stage number

3

- Increase value
- Select previous value, menu item or stage number

4

- Open menu
- Move cursor to the right
- Accept value

Entering values

If a menu item has been entered, the first digit of the current value flashes. Numbers can be increased or decreased by pushing the ▲ and ▼ keys.

The next digit can be selected by pushing the ► key. In order to select the previous digit, the ◀ key must be pushed.

If the last digit (right) has been selected and the ► key is pushed again, a multiplier **k** (kilo) or **M** (mega) can be set using the ▲ and ▼ keys. To accept the value and complete the entry, the ► key must be pushed again.

If an entered value has not been accepted, or if another value is displayed after an input, the entered value has exceeded or fallen below the threshold of the setting range.

An entry can be canceled at any time by pushing the ◀ key. Depending on the actual position, the ◀ key must be repeatedly pushed until the first digit (left) is selected. Pushing the ◀ key again exits the menu item without accepting changes.

Main menu

A menu can be selected by pushing ▲▼; Submenus are entered with ►

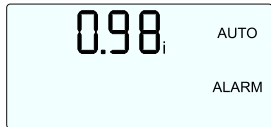
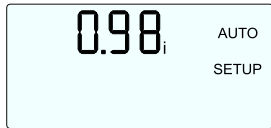
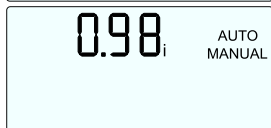
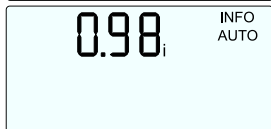
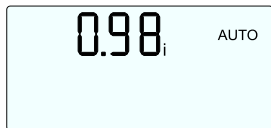

Measurement menu (Using ▲▼)

Retrieve measured values

INFO – Stage database

Contains the reactive power, power losses, amount of switching cycles and operating hours, stage type of each stage

MANUAL – Switching stages manually

Switching stage outputs manually

SETUP – Controller setup

Show and adjust all controller settings

ALARM – Alarm memory

Show the last 10 alarm messages. The newest alarm message is saved in location 1.

INFO – Stage database

Stages can be selected by ▲▼ and entered by pushing ►. The selected stage flashes. Using ▲▼, the following information can be shown.

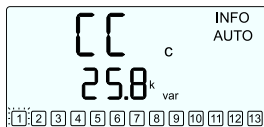

Current capacitor size

The reactive power value refers to the nominal voltage



Capacitor size in percent

Current reactive power to nominal reactive power ratio



Amount of switching cycles

Amount of completed switching operations



Stage type

AUTO: Stage is controlled automatically

FON: Stage is always on

FOFF: Stage is always off

Ffty: Stage has been detected as faulty



Operating hours

Amount of operating hours

MANUAL – Switching stage outputs manually

In order to enter the **MANUAL** menu, the ► key must be pushed for 3 seconds.

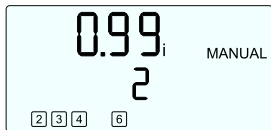

▲▼ to select a stage. The selected stage is shown in the lower part of the display. A stage is switched on or off by pushing the ► button.

The **MANUAL** menu can be exit by pushing the ◀ key.

Important information:

- Only stages of the type **AUTO** can be manually switched.
- The discharge time is considered in manual mode as well. After switching a stage off, it is locked until the discharge time has been expired.
- The measured voltage must be within the set tolerance. If the voltage is out of tolerance, every stage is switched off and cannot be switched on again.
- As soon as the **MANUAL** menu is left, the control automatically starts again.

SETUP – Controller setup

The Quick Start menu (100) and the Expert menus (200 – 800) can be entered by pushing the ► button. The latter one requires the input of a PIN code.

Un **Nominal voltage**

Ct **Current transformer factor**

Pt **Voltage transformer factor**

Ai **Automatic initialization**

The phase angle between voltage and current is determined and which stage outputs are used.

PFC **Control ON, OFF, Hold**

Switching on, off or suspend the control

CP1 **Target-cosφ 1**

Compensation target

St **Switching time**

Delay between switching different stages

Out **Stage type AUTO, FON, FOFF, Flty**

Stages are controlled automatically, are permanently on, permanently off or detected as faulty. **AUTO**, **FON** and **FOFF** can be adjusted and **Flty** stages can be reset.

Automatic initialization (Ai)

The Automatic initialization determines the phase angle between voltage and current and detects which stage outputs are used.

The Automatic initialization can be activated in the SETUP menu (SETUP/100/Ai or SETUP/207 = **YES**) and starts as soon as the voltage is within the tolerance and the measured current is greater than 5 mA. The display shows **Ai run** and the **number** of the active run. At the end of the Ai, the function of the controller must be checked.

NOTE: The Automatic initialization is only possible in conjunction with capacitive stages.

Due to load fluctuations, it may happen that the Ai does not correctly recognize used stage outputs or is aborted. The latter one is displayed by the error message **Ai / Abrt**. In this case, the control is stopped.

If the Automatic initialization is not successful after several attempts, the correct phase correction angle must be set manually (SETUP/206). Moreover, the stage types must be adjusted manually (SETUP/100/Out or SETUP/403) and the control must be started again (SETUP/100/PFC or SETUP/310 = **ON**).

Automatic stage size detection

If stage detection is activated (SETUP/308 = **YES**), the CX plus determines the size of the stages automatically during each switching operation. The detected sizes are stored in the stage database. There, a stage power loss can be monitored.

If the controller cannot detect a power grid reaction during the first three switching operations, the stage type of the affected stage is set to **FOFF** and it is not taken into account by the control.

NOTE: The automatic stage detection is only possible in conjunction with capacitive stages. The use of inductive stages requires a manual input of the stage sizes (SETUP/402).

Detect faulty stages

Stages whose size has already been adopted are classified as faulty by the control system after three successive switching operations without a power grid reaction. A new check is performed after 24 hours.

Faulty stages have the stage type **Filty** and are indicated by a flashing stage symbol.

The cause of a faulty stage could possibly be a defective fuse, a defective power contactor, a defective thyristor switch or a defective capacitor stage.

Most important Alarm and Error messages

| | | |
|------------------|-------|---|
| U | ALARM | The measured voltage is out of the set tolerance. |
| I Lo | ALARM | The measured current is smaller than 5 mA. |
| I hi | ALARM | The measured current is higher than 6 A. |
| PFC | ALARM | The compensation target cannot be reached. |
| HARU | ALARM | The set THD voltage threshold has been exceeded. |
| HARl | ALARM | The set THD current threshold has been exceeded. |
| StEP/FltY | ALARM | At least one stage is faulty. |
| SPL/Nr | ALARM | The reactive power of at least one stage has fallen below 75 % of the initial power value. |
| thi | ALARM | The second temperature threshold has been exceeded. |
| OPh | ALARM | The set operating hours of the controller have been exceeded. |
| OPC/Nr | ALARM | The maximum switching cycles threshold of at least one stage has been exceeded. |
| OPh/Nr | ALARM | The set operating hours of at least one stage have been exceeded. |
| Ai/Abrt | ALARM | The Automatic initialization has been aborted due to an error. The control is switched off. |

Factory settings

| | | | |
|---|---------------|---|---------------|
| SETUP/100 Quick Start | open | 304/ Target-cosϕ 2 if P export | NO |
| Un/ Nominal voltage | 400 V | 305/ Switching time | 10 s |
| Ct/ Current transformer factor | 1 | 306/ Sw. time stage exchange | 2 s |
| Pt/ Voltage transformer factor | 1 | 307/ Stage exchange | YES |
| Ai/ Start Ai | NO | 308/ Stage detection | YES |
| PFC/ Control | ON | 309/ Block faulty stages | YES |
| CP1/ Target-cosϕ 1 | 1 | 310/ Control | ON |
| St/ Switching time | 10 s | 311/ Control algorithm | 1 |
| Out/ Stage type | AUTO | 312/ Reactive power offset | 0 var |
| | | 313/ Asymmetry factor | 1 |
| SETUP/200 Measurement | locked | 314/ Switch off if Q is cap | NO |
| 201/ Nominal voltage | 400 V | 315/ Distribute sw. operations | NO |
| 202/ Current transformer factor | 1 | 316/ Detect faulty stages | YES |
| 203/ Voltage transformer factor | 1 | | |
| 204/ Voltage tolerance | 10 % | SETUP/400 Stage database | locked |
| 205/ Meas. connection | U-LN | 401/ Discharge time | 75 s |
| 206/ Phase correction angle | 0 | 402/ Nominal stage size | c 3 var |
| 207/ Start Ai | NO | 403/ Stage type | AUTO |
| 208/ Sync. frequency | AUTO | 404/ Switch operat. counter | 0 |
| 209/ Temperature offset | 0 °C | 405/ Operat. hours counter | 0 h |
| | | 406/ Fan relay as stage output | NO |
| SETUP/300 Control | locked | | |
| 301/ Control sensitivity | 60 % | | |
| 302/ Target-cosϕ 1 | 1.00 | | |
| 303/ Target-cosϕ 2 | 0.95 i | | |

| | | | |
|---|---------------|-----------------------------|---------------|
| SETUP/500 Alarm | locked | SETUP/600 Reset menu | locked |
| 501/ Reset alarms manually | NO | 601/ Factory reset | NO |
| 502/ THD-U threshold | 20 % | 602/ Stage database | NO |
| 503/ Switch off stages | NO | 603/ Operating hours | NO |
| 504/ THD alarm delay | 60 s | 604/ Average power factor | NO |
| 505/ Stop control if I=0 | NO | 605/ Max. temperature | NO |
| 506/ Service alarm | NO | 606/ Alarm memory | NO |
| 507/ Max. OPc stages | 500 k | 607/ Info firmware | --- |
| 508/ Max. OPh controller | 65.5 kh | 608/ Change password | 242 |
| 509/ Max. OPh stages | 65.5 kh | 609/ Restart First Setup | NO |
| 510/ THD-I threshold | 50 % | | |
| 511/ Digital input logic | YES | SETUP/700 Modbus | --- |
| 512/ TEMP1 threshold | 30 °C | Baud rate | 19.2 k |
| 513/ TEMP2 threshold | 55 °C | Parity and stop bits | EVEN |
| 514/ Control alarm | NO | Slave address | 1 |
| 515/ Faulty stages alarm | NO | | |
| 516/ Stage power loss alarm | NO | SETUP/800 System | locked |
| 517/ Flashing display | NO | 801/ Backlight during | NO |
| 518/ Digital input function | CP2 | Commissioning mode | |
| 519/ I-Low alarm suppr. | YES/NO | 802/ Backlight delay time | 0.25 h |
| 520/ Switch off active stages if digital input alarm | NO | | |
| 521/ I-Low alarm | YES | | |
| 522/ I-High alarm delay | 10 s | | |
| 523/ Switch-off interval | 60 s | | |

Specifications

| | |
|-------------------------------|---|
| Voltage measurement / supply: | Connection: Single phase Range: 90 – 550 V AC, 45 – 65 Hz Protection: Max. 6 A Power consumption: 6 VA Transformer factor: Adjustable 1.0 ... 350.0 |
| Current measurement: | Connection: Single phase Range: 5 mA – 5 A Transformer factor: Adjustable 1 ... 9600 |
| Stage outputs: Option -xxR | 6 or 12 Stage outputs Type: Relay, normally-open, potential-free Supply: Common, max. 10 A Swit. capacity per relay: 250 V AC / 5 A 400 V AC / 1 A 48 V DC / 1 A 110 V DC / 0.2 A Type: Transistor, normally-open, open collector output Supply: Common, max. 1,2 A Switching capacity per transistor: 100 mA / 8 – 48 V DC |
| Temperature measurement: | NTC: Under the housing cover Accuracy: + 5 °C |

| | |
|----------------------|--|
| Alarm output: | |
| Default | Type: Relay, normally-open, potential-free Switching capacity: 5 A / 250 V AC |
| Option -nc | Type: Relay, normally-closed, potential-free Switching capacity: 5 A / 250 V AC |
| Fan output: | Type: Relay, normally-open, potential-free Switching capacity: 250 V AC / 5 A 400 V AC / 1 A 48 V DC / 1 A 110 V DC / 0.2 A |
| Digital input: | Logic: Adjustable, High- or low-active Input signal: 90 – 250 V AC |
| Service Interface: | For service purpose only |
| Modbus: | |
| Default | Unassembled |
| Option -MB | Protocol: Modbus-RTU Interface: RS485 Common-mode range: -7 – 12 V Differential-mode range: -12 – 12 V Output current: -60 – 60 mA |
| Ambient temperature: | Operating: -20 °C – 70 °C Storing: -40 °C – 85 °C |

| | |
|-------------------------|--|
| Humidity: | Range: 0 % – 95 % Condensation: Not allowed |
| Overvoltage category: | 300 V _{LN} / 519 V _{LL} → CAT III 519 V – 550 V → CAT II Degree of contamination → 2 |
| Standards: | IEC 61010-1, IEC 61000 6-2, IEC 61000 6-4: Level B, IEC 61326-1, UL 61010 |
| Compliance and Listing: | CE, NRTL (C TÜV Süd), EAC, UKCA |
| Connections: | Type: Screw terminals, pluggable Cross section: Max. 4 mm ² |
| Housing: | Front: Plastic housing (UL94 V-0) Back: Metal cover |
| Protection class: | Front: IP41 Back: IP20 |
| Weight: | Approx. 0,6 kg |
| Dimensions: | Device: H x B x T: 144 x 144 x 58 mm Cut-out: H x B: 138 (+0,5) x 138 (+0,5) mm |

Operation of BLR-ACX Plus in High Voltage and Medium Voltage compensation panels

The below list is showing the parameters of the BLR-ACX Plus which need special attention for HV and MV compensation panels.

Attention: When putting the BLR-ACX in operation, the countdown for **“AI”** has to be stopped by pushing the **“esc” button**.

Un = Adapt nominal voltage to local conditions

Ct = Adapt Ct ratio to local conditions

Pt = Adapt Pt ratio to local conditions

St = Adapt Switching time to local requirements

208 = Set item 208 to “No” and switch off the countdown for “AI”

308 = Set item 308 to “No2” and switch off the automatic step size detection.

401 = Adapt Discharge time to local conditions

402 = Adjust step sizes

Attention: When resetting the BLR-ACX Plus by using menu Item 601 or 602, all adjusted values will be reset to the original factory settings.

When using factory settings for High voltage compensation a proper and safe operation is not possible!